**User's
Manual**

**4-CH Timing Measurement Module
WE7521**

Thank you for purchasing the WE7521 4-CH Timing Measurement Module for WE7000 PC-Based Measurement Instruments.

This user's manual contains useful information about the WE7521's functions, how to connect it to a measuring station, operations of the software on the PC, and troubleshooting. This manual assumes that you will be using the WE7000 Control Software that is included with the measuring station.

The manual listed below contains general information about the WE7000 (it primarily describes the operations of the measuring station, the optical interface module, the optical interface card, and the WE7000 Control Software) and is included with the measuring station.

Manual Title	Manual No.
WE7000 User's Manual	IM707001-01E

To ensure correct use of the instrument, please read this manual thoroughly before beginning operation.

After reading the manual, keep it in a convenient location for quick reference whenever a question arises during operation.

Notes

- **The contents of this manual describe the WE7000 Control Software version 4.0.3.0 and module software version 3.01. The operating procedures and screen contents described in this manual may differ from those in other versions of the software.**
- The contents of this manual are subject to change without prior notice as a result of improvements in the instrument's performance and functions.
- Every effort has been made in the preparation of this manual to ensure the accuracy of its contents. However, should you have any questions or find any errors, please contact your nearest YOKOGAWA dealer.
- Copying or reproducing all or any part of the contents of this manual without the permission of Yokogawa Electric Corporation is strictly prohibited.

Trademarks

- Microsoft, Windows, and Windows NT are either registered trademarks or trademarks of Microsoft Corporation in the United States and/or other countries.
- Adobe and Acrobat are trademarks of Adobe Systems Incorporated.
- All other company and product names used in this manual are trademarks or registered trademarks of their respective companies.

Revisions

1st Edition: January 2001

Checking the Contents of the Package

Unpack the box and check the contents before operating the instrument. If some of the contents are not correct or missing or if there is physical damage, contact the dealer from which you purchased them.

Measurement Module

Check that the model name given on the name plate matches those on the order.

MODEL

Model	Description
707521	WE7521 4-CH Timing Measurement Module

NO.

When contacting the dealer from which you purchased the instrument, please give them the instrument number.

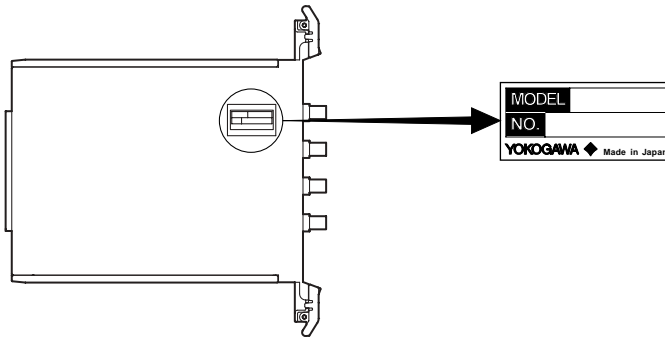

Standard Accessories

The standard accessories below are supplied with the instrument. Check that all contents are present and that they are undamaged.

User's manual (1)
IM707521-01E

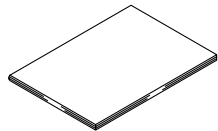

Helpful Information About This Manual

Structure of the Manual

This user's manual consists of the following sections.

Chapter	Title	Description
1	Explanation of Functions	Explains the system configuration and functions.
2	Hardware Preparation	Explains how to install the module into the measuring station and how to connect the input.
3	Troubleshooting and Maintenance	Explains the procedures for troubleshooting and self testing.
4	Specification	Explains the specifications of the module.
Index		Index of contents.

Symbols Used in the Manual

- **Unit**

k: Denotes 1000. Example: 100 kHz

K: Denotes 1024. Example: 720 KB

- **Bolded Characters**

Characters written in bold mainly refer to on-screen elements and hardware controls.

- **Notes**

The following symbols are used in this manual.



A symbol affixed to the instrument. Indicates danger to personnel or instrument and the operator must refer to the user's manual.

The symbol is used in the user's manual to indicate the reference.

WARNING

Describes precautions that should be observed to prevent injury or death to the user.

CAUTION

Describes precautions that should be observed to prevent minor or moderate injury, or damage to the instrument.

Note

Provides information that is important for operating the instrument properly.

Contents

Checking the Contents of the Package	2
Helpful Information About This Manual	3
Chapter 1 Explanation of Functions	
1.1 Measurement Principles, System Configuration, and Block Diagram	1-1
1.2 Operation Panel	1-3
1.3 Operation Mode and Measurement Functions	1-5
1.4 Setting the Measurement Conditions	1-8
1.5 Automatic Save of Measured Data, File Format Conversion, and Other Settings	1-13
1.6 Synchronizing to Other Modules Using the Bus Trigger/Time Base Signal	1-14
1.7 Data Storage Format When in Time Stamp Mode	1-16
1.8 Measurement Accuracy	1-17
1.9 Names and Function of Sections	1-19
Chapter 2 Hardware Preparation	
△ 2.1 Installing the Module into the Measuring Station	2-1
△ 2.2 Connecting the Input Cable	2-3
Chapter 3 Troubleshooting and Maintenance	
3.1 Troubleshooting	3-1
3.2 Self Test	3-2
3.3 Maintenance	3-3
Chapter 4 Specifications	
4.1 Performance Specifications	4-1
4.2 Default Values (Factory Default Settings)	4-4
4.3 General Specifications	4-5
4.4 Dimensional Drawings	4-6
Index	Index-1

1.1 Measurement Principles, System Configuration, and Block Diagram

The WE7521 4-CH Timing Measurement Module achieves a time resolution of 5 ns by using a multiphase clock in the measurement of periods and time intervals.

Measurement Principles

The method by which the measurement module achieves a 5-ns time resolution is explained using an example in which period T of an input signal is measured.

The figure below shows the timing chart of the internal clock and the input signal.

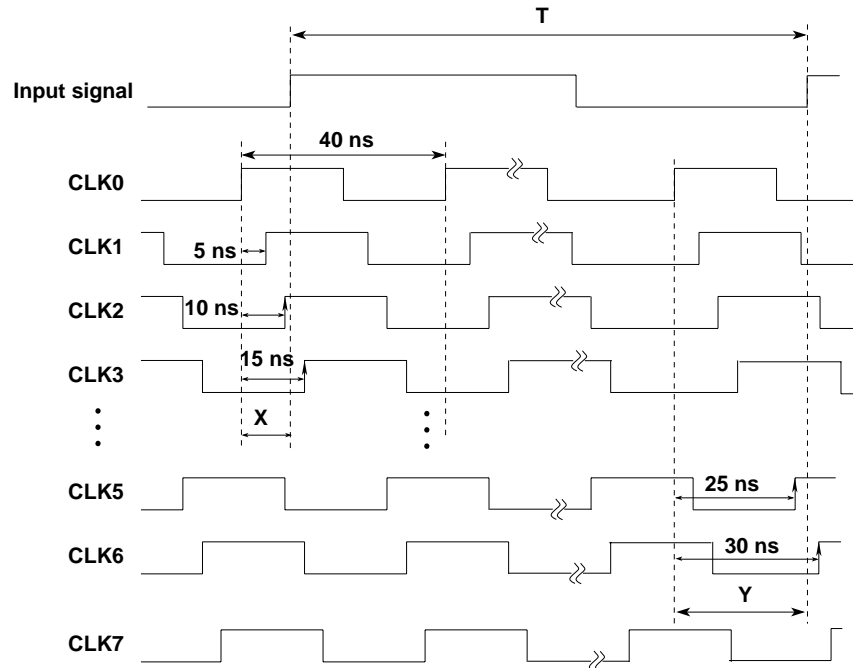

The frequency of CLK0 through CLK7 in the figure above is 25 MHz. The phase of each clock is offset by 5 ns creating an 8-phase clock.

By measuring when the rising edge of the input signal occurs against the 8-phase clock, measurements with a period shorter than the period of the reference clock is achieved. Since the rising edge of the input signal appears between CLK2 and CLK3, the module determines that

$$X = 15 \text{ ns}$$

by considering the phase offset from the reference clock (CLK0). Since the other rising edge appears between CLK5 and CLK6, the module determines that

$$Y = 30 \text{ ns.}$$

In the example of the figure above, if three clock cycles of the reference clock are counted during the measurement, period T of the input signal is found to be

$$T = 40 \text{ ns} \times 3 - 15 \text{ ns} + 30 \text{ ns} = 135 \text{ ns}$$

from the phase values at the rising and falling edges. By using an 8-phase clock in this way, a 5-ns resolution can be achieved.

System Configuration

The following is an example in which the WE7521 4-CH Timing Measurement Module is installed into the measuring station and the measuring station is connected to the PC with the optical fiber cable.

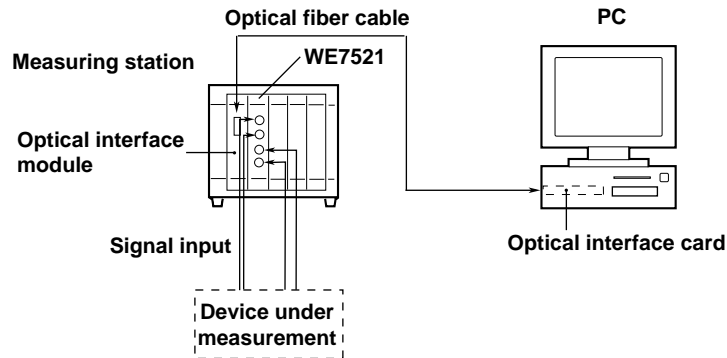

Block Diagram

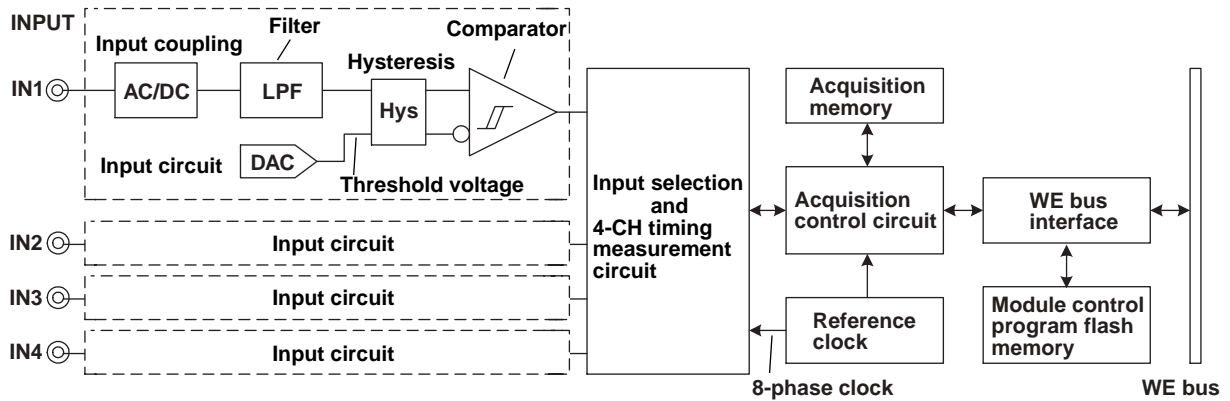

The input signal to terminals IN1 to IN4 is converted to a binary signal according to the settings such as the input coupling, filter, hysteresis, and threshold voltage. The four signals that have been converted to binary values are selected in the timing measurement circuit, and the time is measured using the 25 MHz and 8-phase clocks (see the previous page) that the reference clock generates.

In the acquisition control circuit, the measured values are sampled by synchronizing to a clock up to 500 kHz. The sampled values are written to the acquisition memory every specified sampling interval. The measured values that are stored in the acquisition memory can be read by a PC according to the control program that is stored in the module.

1.2 Operation Panel

The WE7000 Control Software that is installed in the PC is used to control the WE7521 4-CH Timing Measurement Module. The WE7000 Control Software displays operation panels similar to those shown in the figure below. This user's manual does not explain the operations of the operation panel or waveform monitor. For the operations of these items, see the online help that is provided with the WE7000 Control Software.

Settings in Counter Mode

Select the input coupling

Select the measurement function

Set the threshold level

Select the input to be measured/slope

Set the input filter

Select the hysteresis width

IN1 to IN4: Input number
CH1 to CH4: Channel number
(for identifying the measurement data)

Start/Stop measurement

Turn ON/OFF waveform monitor

Select the check box during continuous measurements (only during the trigger/gate mode)

Select the sampling interval

Select the acquisition mode

Set the record length

Set the number of acquisitions (Number of memory block used)

When switching to time stamp mode

Set the number of memory partitions

- Settings on the Trig tab

Select the trigger source

Select the input when trigger source is set to Input

Select the trigger slope

Trigger type and threshold level settings appear if the trigger source is set to [Measure]. Selection of the bus trigger detection method appears if the trigger source is set to [BUSTRG].

Set the pretrigger

Set the trigger hold off

- Settings on the Misc tab

Select the time base

Turn ON/OFF data hold

Set the hysteresis direction

Set the slope of the time base source

Select the input when time base source is set to Input

Settings in Time Stamp Mode

Turn ON/OFF measurement
Select the input coupling
Select the slope
Set the threshold level
Set the input filter

The screenshot shows a software interface for a 4-channel timing measurement module. It features a table for channel settings and two radio button groups for hysteresis and operation mode. The table has columns for 'On', 'Coupling', 'Slope', 'Level(V)', 'Filter', and 'Hys'. Channel IN1-4 are all set to 'On', 'DC' coupling, 'Rise' slope, '0.0' level, and 'Off' filter. The 'Hys' column has checkboxes that are currently unchecked. Below the table is a 'Start' button. At the bottom, there are two radio button groups: 'Hys Type' with 'Upper', 'Center', and 'Lower' options; and 'Operation Mode' with 'Counter' and 'Time Stamp' options. The 'Time Stamp' mode is selected.

Slot	On	Coupling	Slope	Level(V)	Filter	Hys
IN1	<input checked="" type="checkbox"/>	DC	Rise	0.0	Off	<input type="checkbox"/>
IN2	<input checked="" type="checkbox"/>	DC	Rise	0.0	Off	<input type="checkbox"/>
IN3	<input checked="" type="checkbox"/>	DC	Rise	0.0	Off	<input type="checkbox"/>
IN4	<input checked="" type="checkbox"/>	DC	Rise	0.0	Off	<input type="checkbox"/>

Select the hysteresis width

Start

Start/Stop measurement

Hys Type
 Upper
 Center
 Lower

Operation Mode
 Counter
 Time Stamp

When switching to counter mode

Select the hysteresis direction

1.3 Operation Mode and Measurement Functions

Operation Mode

The following two operation modes are available.

Counter Mode

Able to measure one of five parameters—period, time interval, totalize count, up and down count, and frequency ratio—of four input signals. The measured values are written to the acquisition memory every specified sampling interval. For details on the measurement functions in this mode, see “Measurement Functions in the Counter Mode” below.

Note

- Note that the measurements of time interval, up and down count, and frequency ratio apply to input signals within the same module. You cannot make measurements on these parameters on two input signals across linked modules.
- On the operation panel, set the input conditions such as input coupling for each input (IN1 to IN4). Then, assign the measurement function or the input to be measured to channel numbers (CH1 to CH4) that are used as identification numbers for the measured data.

Time Stamp Mode

Records the time in units of 5 ns when any of the four input signals change. The recorded time is a relative time with respect to the start of the measurement. Up to 4 Mpoints of time data can be recorded.

You can select the slope for detecting the point of change from rising (Rise), falling (Fall), or both rising and falling (Both) edges. The only acquisition mode available for this mode (see page 1-9) is [Free Run].

- When set to Rise

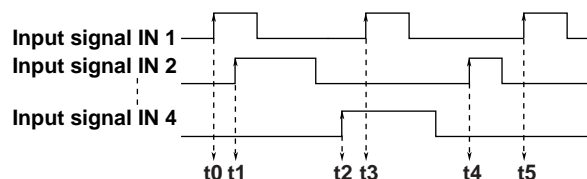

- When set to Both

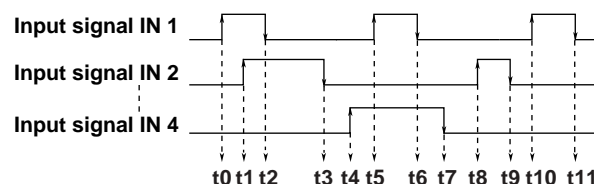

The minimum pulse width needed in detecting the slope is 200 ns within a single signal and 5 ns between two signals (as shown below).

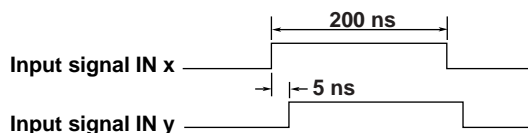

For the format of the time data that is recorded, see section 1.7, “Data Storage Format during Time Stamp Mode.” Note that there are no monitor or viewer programs available for inspecting the time data.

Measurement Functions in Counter Mode

You can select from the following functions.

Period

Measures the period of the input signal.

The measurement range is 100 ns to 20 s. If the period is greater than 20 s and cannot be measured, the measured value becomes 0xffffffff (invalid value).

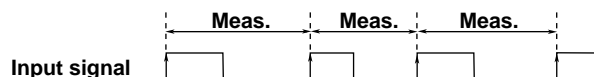

Time Interval (TI)

Measures the time from the rising (falling) edge of the specified input signal to the rising (falling) edge of the another specified input signal.

The measurement range is 100 ns to 20 s. If the time interval is greater than 20 s and cannot be measured, the measured value becomes 0xffffffff (invalid value).

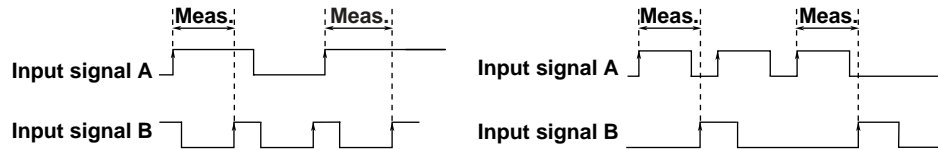

Totalize Count (Totalize or Totalize (Gate))

If the measurement function is set to Totalize, the number of input signal pulses is integrated from the time the measurement is started to the time the measurement is stopped. The measurement range is 0 to 536,870,911. If the measured value exceeds 536,870,911, the value is reset to zero and counting continues. The measured value is reset to 0 when you restart the measurement (also when performing the Repeat operation in trigger mode (see page 1-9)).

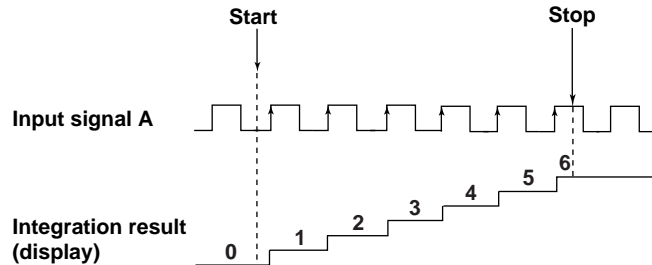

If the measurement function is set to Totalize(Gate), the counting can be controlled using the pulse width of the specified input signal as a gate as shown below.

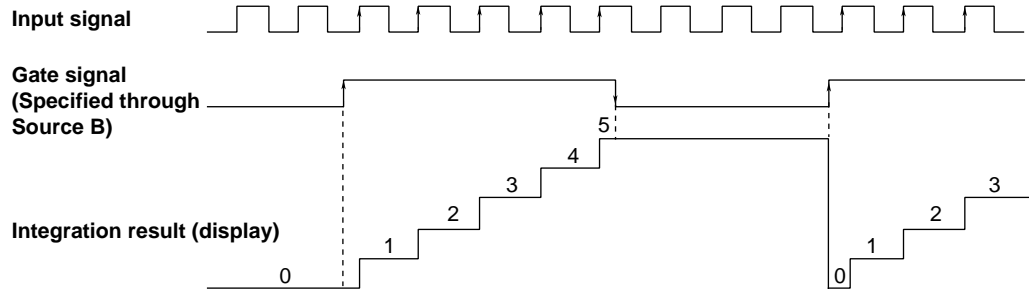

Up and Down Count (UpDown1/UpDown2/UpDown4)

Detects the rising/falling edge of the specified input signal and the rising/falling edge of the other specified input signal and increments/decrements the counter. The combinations of input signals (specified through Source A) that can be specified are [IN1] and [IN2] or [IN3] and [IN4].

The following three types of counting methods are available and you can select one.

- ×1

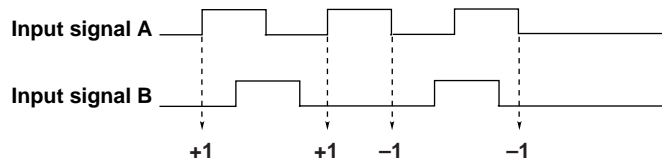

- ×2

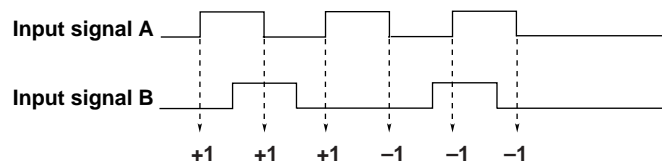

- ×4

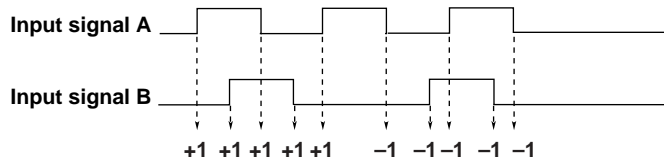

You can control the start and stop of the counter using the start and stop of the measurement. In addition, the reset signal (specified through Source B) can be used to control the start and stop of the counter as shown below. The measured value is reset to 0 when you restart the measurement (also when performing [Repeat] operation in the trigger mode (see page 1-9)).

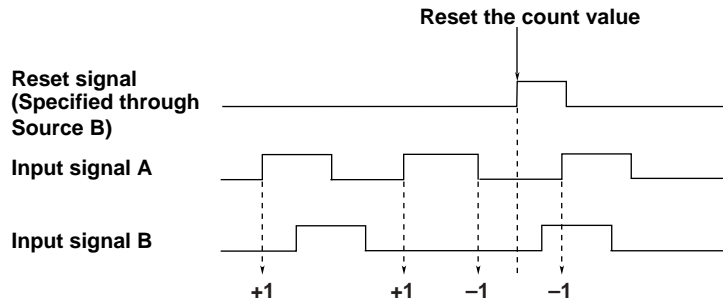

The measurement range is $-268,435,456$ to $268,435,455$. If the count value exceeds $268,435,455$, it is reset to $-268,435,456$ and the increment/decrement operation continues. Similarly, if the value falls below $-268,435,456$, it is reset to $268,435,455$ and the increment/decrement operation continues.

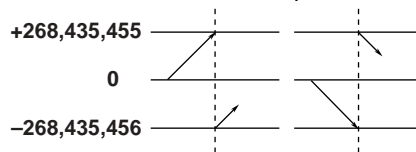

Frequency Ratio (Ratio ×1, Ratio ×16, Ratio ×128, Ratio ×1024)

The frequency ratio is determined by setting the gate to 1 period × multiplication factor (×1, ×16, ×128, or ×1024) of the specified input signal and counting the number of pulses of the other specified input signal. You can increase the resolution of the measurement by setting a high multiplication factor. However, setting a high multiplication factor causes the measurement range to become narrow as follows:

- ×1: 0 to 536,870,911
- ×16: 0 to 33,554,431.9
- ×128: 0 to 4,194,303.99
- ×1024: 0 to 524,287.999

- When set to ×1

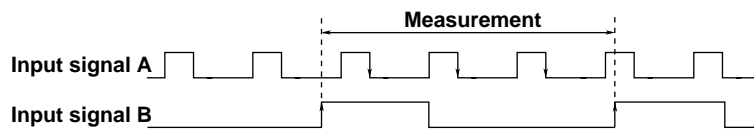

- When set to ×16

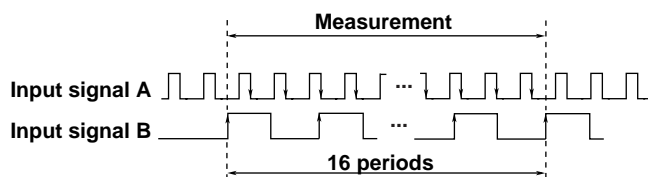

Frequency ratio = measured value/16

1.4 Setting the Measurement Conditions

For Counter Mode

Input Coupling

Select which component of the input signal to acquire.

AC: Acquire only the AC component of the input signal. The lower limit of the input frequency is approximately 10 Hz.

DC: Acquires all the components (DC and AC) of the input signal.

Input to Be Measured/Slope (Source A and Source B)

Select the input (IN1 to IN4) to be measured or to be used as a gate and the slope (Rise or Fall) for detecting the point of change of the input signal according to the measurement function (see pages 1-5 to 1-7). However, for up and down count, select the combination of the input to be measured through Source A and the input used to reset the counter through Source B.

- Period
Source A: IN1_Rise/IN1_Fall/IN2_Rise/IN2_Fall/IN3_Rise/IN3_Fall/IN4_Rise/IN4_Fall
- Time interval
Source A: IN1_Rise/IN1_Fall/IN2_Rise/IN2_Fall/IN3_Rise/IN3_Fall/IN4_Rise/IN4_Fall
Source B: Same as Source A
- Totalize count
Source A: IN1_Rise/IN1_Fall/IN2_Rise/IN2_Fall/IN3_Rise/IN3_Fall/IN4_Rise/IN4_Fall
Source B (Gate for Totalize (Gate)): IN1/IN2/IN3/IN4
- Up and down count
Source A: IN1-IN2/IN3-IN4
Source B (input used to clear the counter): Off/IN3/IN4 (when Source A is IN1-IN2),
Off/IN1/IN2 (when Source A is IN3-IN4)
- Frequency ratio
Source A: IN1_Rise/IN1_Fall/IN2_Rise/IN2_Fall/IN3_Rise/IN3_Fall/IN4_Rise/IN4_Fall
Source B: Same as Source A

Input Threshold Level

Specify the threshold level used to detect the point of change (rising or falling edge) of the input signal. This value is also used as a level for detecting the trigger slope (see page 1-11) when an input signal is used as a trigger source.

Input Filter

You can set a low-pass filter used to eliminate high-frequency noise from the input signal. Select from Off, 1kHz, 10kHz, or 100kHz.

Hysteresis Width (Hys)

By default, the hysteresis width is set to NORMAL (approximately 0.8 Vpp) as a measure against noise during the detection of the point of change of the input signal. If you select the Hys check box, the hysteresis width is set to WIDE (approximately 2.5 Vpp). This setting also applies to the detection of the trigger point (page 1-11).

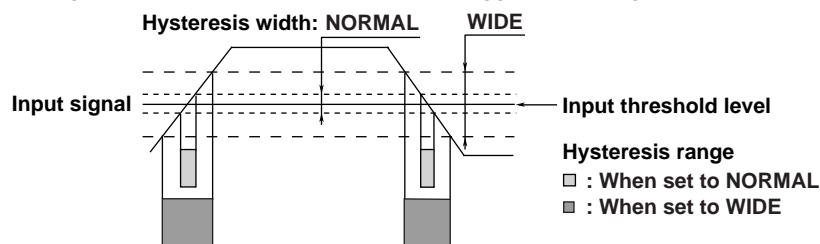

Hysteresis Direction (Hys Type)

You can select the direction in which hysteresis is shifted. The default value is Center. As shown in the figure below, you can alleviate the trigger level timing error (see page 1-17) when detecting the point of change of input by setting the appropriate direction suitable for the selected slope.

This setting also applies to the detection of the trigger point (page 1-11).

Upper: Shift the hysteresis upward with respect to the threshold level.

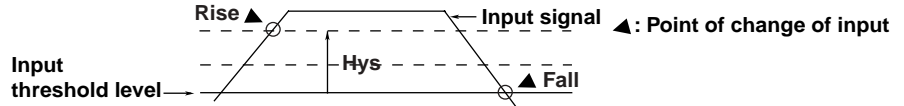

Center: Apply the hysteresis on both sides of the threshold level.

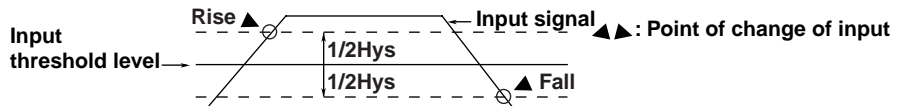

Lower: Shift the hysteresis downward with respect to the threshold level.

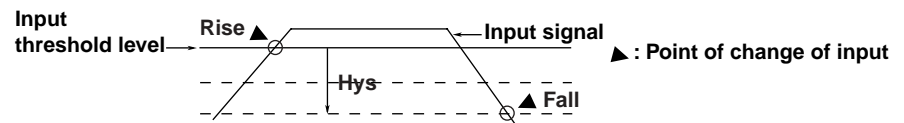

Acquisition Mode

Select the method used in writing the measured values from the following four modes.

- Trigger mode (Triggered)

The measured values are written to the acquisition memory according to the specified trigger condition (see page 1-11). After writing the specified record length of values, the operation stops. In this mode, the acquisition memory can be partitioned and the measured values can be written to these individual memory blocks each time triggering occurs. If the Repeat check box* is selected, the operation repeats until the next time the Start button is clicked.
- Free run mode (Free Run)

Writing of the measured values starts immediately upon starting the measurement. The writing operation stops when the measurement is stopped.
- Gate (level) mode (Gate(Level))

The measurement values are written during the time when the specified trigger condition is satisfied (gate period). If the specified record length of values is written before the gate period ends, the writing operation stops at that point. The operation repeats the number of times specified by the number of acquisitions. You can halt the operation before this number is reached by manually stopping the measurement.

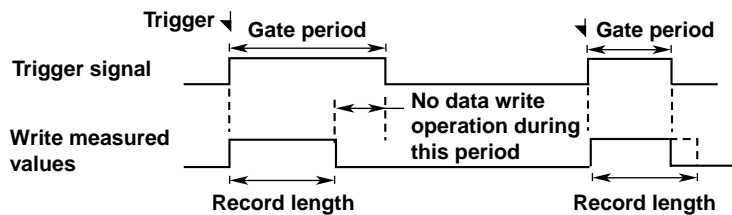

- Gate (edge) mode (Gate(Edge))

Write operation of values starts when the specified trigger condition is satisfied and pauses when the trigger condition is no longer satisfied. When the trigger condition is satisfied again, the write operation starts at a new memory block. The operation repeats the number of times specified by the number of acquisitions. You can halt the operation before this number is reached by manually stopping the measurement.

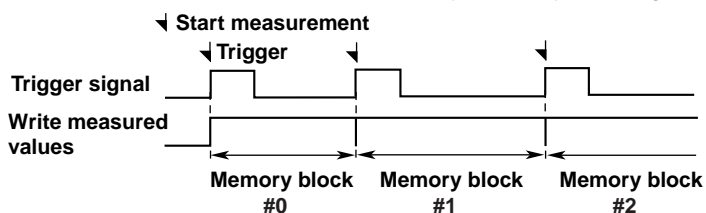

Sampling Interval

This is the interval at which the measured values are written to the acquisition memory when the time base is set to “internal clock [Internal].” The selectable range varies depending on the acquisition mode as follows:

- During trigger/gate mode
2 μ s to 10 s (1 μ s steps).
- During free run mode
The selectable range is 1 ms to 10 s (1 μ s steps).

By default, when the duration over which the measured value is obtained is longer than the sampling interval, the previous measured value is written to the acquisition memory until the new measured value is obtained (see the settings of “Data Hold” on page 1-11).

Memory Partition

During the trigger mode, you can divide the acquisition memory into multiple blocks and write the values to the memory blocks in order every time the trigger occurs. You can divide the memory into 1, 2, 4, 8, 16, 32, 64, 128, or 256 partitions.

Record Length

When the acquisition mode is set to trigger or gate (level), you can partition the memory and specify the number of points of measured values to be written to one block of the acquisition memory. Note that for the following selectable ranges, a limit as defined by $\text{sampling interval} \times \text{record length} \geq 5 \text{ ms}$ exists.

- During trigger mode
The selectable range is 2 to 1,048,576 (1M)/the number of memory partitions. The record length is set to *maximum record length/the number of memory partitions* when 0 is specified.
- During gate (level) mode
The selectable range is 2 to 1,048,576 (1M)/the number of memory partitions. The record length is set to the maximum record length when 0 is specified. In this case, the memory is partitioned according to the satisfied and unsatisfied conditions of the trigger. The maximum number of memory blocks that can be created in this way is 256.

Number of Acquisitions (No. of Acquisitions)

When the acquisition mode is set to Triggered or Gate (Level/Edge) you can partition the memory and specify the number of acquisitions to be carried out. The range is 1 to 65,535 times. However, the operation varies depending on the acquisition mode.

- When in trigger mode
You can only specify 1 for the number of acquisitions, if the number of memory partitions is set to 1.
- When in gate (level) mode
If the record length is greater than or equal to half the maximum record length, you can only specify 1 for the number of acquisitions.

Time Base (Time Base/Input Source/Slope)

Measured values can be sampled not only by using the clock signal generated within the module, but also by using clock signals from external sources or by signals generated by other modules.

Internal: Internal clock

BUSCLK: Input signal (CMNCLK) according to the trigger source/time base source/arming setting (see section 4.6, “Setting Trigger Source/Time Base Source/Arming” in the WE7000 User’s Manual (IM707001-01E)).

Input: Specified input signal

You need to select the target input using the Input Source box and the edge, rising or falling, of the input signal used to sample the measured values using the Slope box. The Input Source list displays the slot number and the input terminal number, as in Slot1-IN1. When the modules are linked, only the input of the master module (module with the smallest slot number) is applicable.

Trigger Source (Source/Input Source/Measure Source)

Select the signal (trigger signal) used to detect the trigger point (activate the trigger) for writing the measured values to the acquisition memory.

Input: Input signal (includes the input signal of linked modules)

You need to select the target input using the Input Source box. The Input Source list displays the slot number and the input terminal number, as in Slot1-IN1.

Measure: Measured value

You need to select the target measured value using the Measure Source box. The Measure Source list displays the slot number and the channel number to which the measured value is assigned, as in Slot1-Ch1.

BUSTRG: Bus signal (BUSTRG1/(BUSTRG2) of the WE bus

Trigger Slope (Slope)

When the input signal is used as a trigger source, select the trigger slope from the following five choices:

- Rise/Fall/Both (Edge trigger)
With this setting, the trigger occurs when the input signal changes from below the input threshold level to above the threshold level (Rise) or from above the threshold level to below the threshold level (Fall). You can have the trigger occur on the rise or fall or both.
- High/Low (State trigger)
With this setting, the trigger occurs when the input signal is above the input threshold level (High) or below the threshold level (Low) or when it enters the high or low condition.

Trigger Type/Threshold

When the measured value is used as a trigger source, set the trigger type and threshold level.

- Trigger type
When the measurement function is totalize count: >= (greater than or equal to the threshold level) or == (equal to the threshold level)
Up and down count: >= (greater than or equal to the threshold level), == (equal to the threshold level), or <= (less than or equal to the threshold level)
Other: >= (greater than or equal to the threshold level) or <= (less than or equal to the threshold level)
- Threshold level
Specify the threshold level of measured values used to detect the trigger. The trigger is detected on the edge of the signal. The selectable range is the measurement range of the corresponding measurement function.

Bus Trigger Detection (Condition)

When the trigger source is set to BUSTRG, select the method used to detect the trigger.

Enter: When the bus trigger signal changes from DISABLE to ENABLE

Exit: When the bus trigger signal changes from ENABLE to DISABLE

Both: When the bus trigger signal changes from DISABLE to ENABLE or from ENABLE to DISABLE

True: While the bus trigger signal is ENABLE

False: While the bus trigger signal is DISABLE

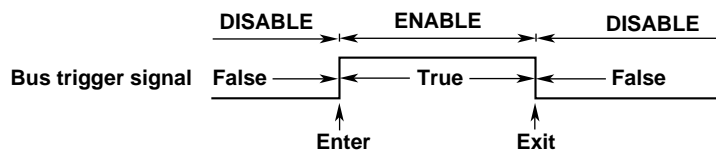

Pretrigger

The measured values before the trigger point can be written to the acquisition memory. Set how many points before the trigger point to begin writing values in the range, 0 to specified record length – 2.

Trigger Hold Off

You can specify the trigger hold off period that is used to temporarily stop the detection of the next trigger once a trigger occurs. The range varies depending on the acquisition mode as follows:

Trigger mode: Record length to 1,048,576 (1M)

Gate (edge) mode: 1 to 1,048,576 (1M)

Data Hold

The measured values are written to the acquisition memory every specified sampling interval. When the duration during which the measured value is obtained is longer than the sampling interval, this setting specifies what to do with the measured value that is to be written to the acquisition memory until the new measured value is obtained. The default setting is On.

On: Hold the previous measured value

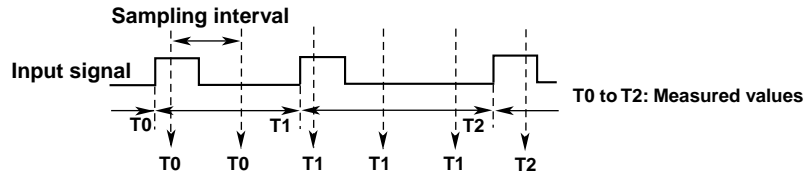

Off: Invalidate* the previous measured value

* The value is set to 0x80000000 when the measurement function is up and down count, or 0xffffffff otherwise. The Waveform Monitor and Viewer do not display invalid measured values.

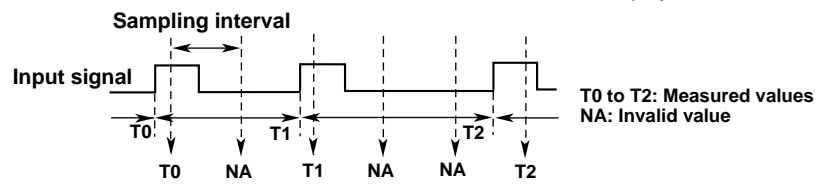

For Time Stamp Mode

Turning ON/OFF Measurement (On)

This setting specifies whether each input (IN1 to IN4) will be measured in the time stamp mode.

Input Coupling

Select which component of the input signal is to be acquired.

AC: Acquire only the AC component of the input signal. The lower limit of the input frequency is approximately 10 Hz.

DC: Acquires all the components (DC and AC) of the input signal.

Slope

Select the slope used to detect the point of change of the input signal.

Rise: Rising edge

Fall: Falling edge

Both: Both rising and falling edges

Input Threshold Level

Specify the threshold level used to detect the point of change (rising or falling edge, for example) of the input signal.

Input Filter

You can set a low-pass filter used to eliminate high-frequency noise from the input signal. Select Off, 1kHz, 10kHz, or 100kHz.

Hysteresis Width (Hys)

By default, the hysteresis width is set to NORMAL (approximately 0.8 Vpp) as a measure against noise during the detection of the point of change of the input signal. If you select the Hys check box, the hysteresis width is set to WIDE (approximately 2.5 Vpp).

Hysteresis Direction (Hys Type)

You can select the direction in which hysteresis is shifted. The default value is Center.

Upper: Shift the hysteresis upward with respect to the threshold level.

Center: Apply the hysteresis on both sides of the threshold level.

Lower: Shift the hysteresis downward with respect to the threshold level.

1.5 Automatic Save of Measured Data, File Format Conversion, and Other Settings

The following functions are contained in the WE7000 Control Software. For the operations of these items, see the online help that is provided with the WE7000 Control Software.

Displaying the Instantaneous Values of Measured Values and the Trend Waveform

The Waveform Monitor of the WE7000 Control Software can display the instantaneous values of measured values or the trend waveform.

Auto Save of Measured Values

In addition to saving the data of the trend waveform on the waveform monitor, you can also have the measured values automatically saved using a trigger or save the values continuously in free run mode.

When in Trigger/Gate Mode

There are two methods of saving the measured values.

- Cyclic
You specify the number of files, and the data is saved in a cyclic pattern within the specified number of files until the measurement is stopped. The newest data is not the file with the largest file number, but the file to which the data was saved immediately before stopping the measurement.
- File number limit
You specify the number of files, and the data are saved up to the specified number and then the operation stops.

When in Free Run Mode

You can select to save the data to one file or to multiple files by specifying the number of data points.

Converting Files of Measured Values

The measured values that are saved in the counter mode can be converted to ASCII data in CSV format or to a physical value in 32-bit floating point format WVF (conforming to IEEE754-1985). This file conversion can also be performed on data saved with the Waveform Viewer or Monitor of the WE7000 Control Software.

The measured values that are saved in the time stamp mode cannot be converted to ASCII data in CSV format. For an explanation of the data format that is required in using these measured values, see section 1.7, "Data Storage Format When in Time Stamp Mode."

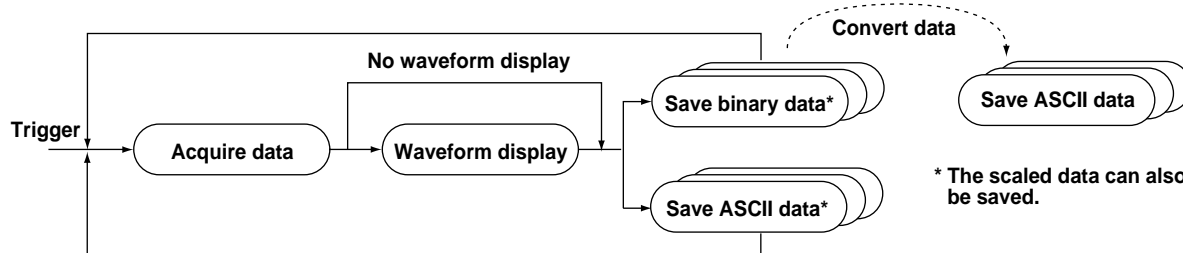

Scale Conversion of the Measured Values

Set the measured values at any two points (VP1 and VP2) and their corresponding physical values (SP1 and SP2). The values at these four points define the scale converting equation ($Y = ax + b$). The measured values are converted to physical values according to this equation. The waveform can be displayed, or the measured values can be saved.

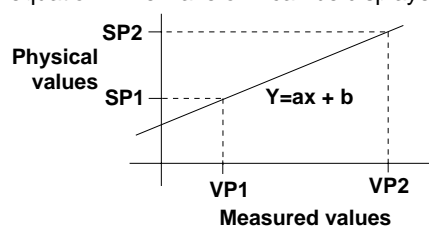

1.6 Synchronizing to Other Modules Using the Bus Trigger/Time Base Signal

Bus Trigger Signal Output

The WE7521 4-CH Timing Measurement Module is capable of outputting a trigger signal (BUSTRG) to the bus in the measuring station on the result obtained by comparing the input signal and the threshold level. Because the comparison between the input signal and the threshold is done in sync with the time base signal, the bus trigger signal (BUSTRG) changes in sync with the time base signal, and *True* is output as shown in the following figure. The bus trigger signal (BUSTRG) is output regardless of the measurement start/stop operation.

- Trigger mode: The bus trigger signal changes on the edge of the input signal and remains True until the next rising edge of the time base signal.

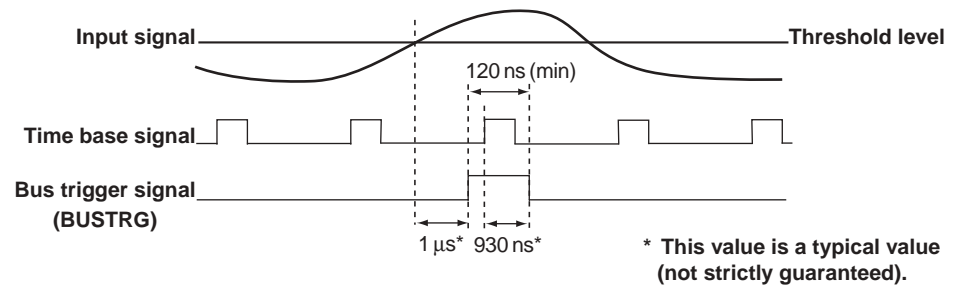

- Gate mode: The bus trigger signal changes on the edge of the input signal and remains True until the rising edge of the time base signal after the next edge of the input signal.

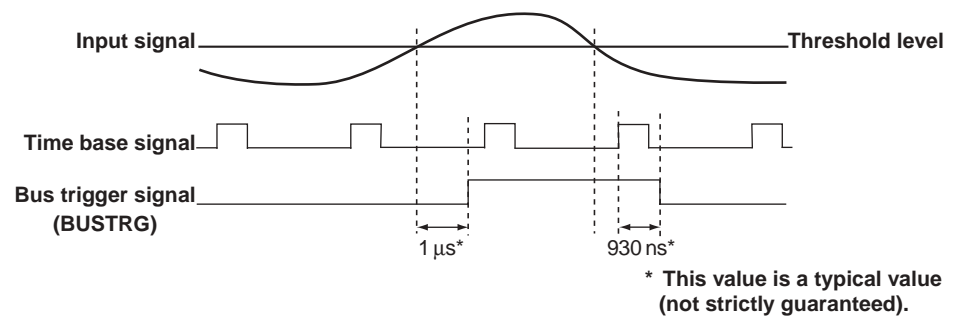

The edge detection of the input signal is performed in sync with the time base signal, but a setup time of 200 ns is required as shown in the figure below.

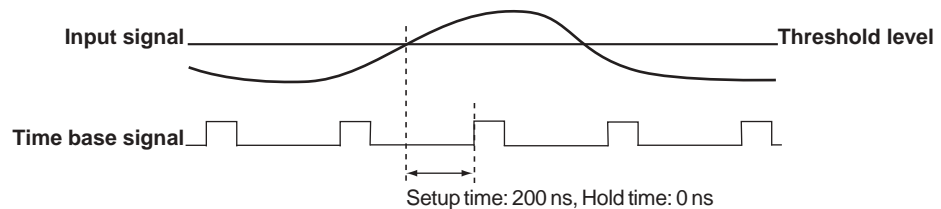

Bus Trigger Signal Input

By setting the trigger source to the bus trigger signal (BUSTRG), the WE7521 is also capable of activating the trigger according to the bus trigger signal (BUSTRG). The setup time and hold time in this case are set as follows:

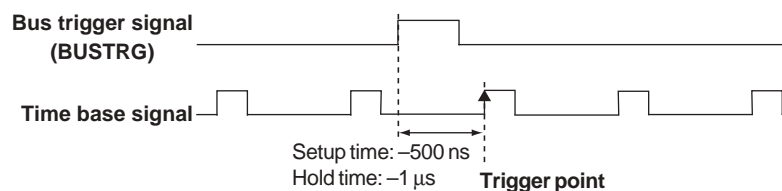

Input/Output of Time Base Signals

The time base signal generated by the internal clock of the WE7521 can be output to the time base signal bus (CMNCLK) in the measuring station. The time difference between the internal clock and the time base signal (CMNCLK) is -10 ns (Typical*). The time base signal is restarted each time the measurement start operation is carried out.

Conversely, the WE7521 can input and synchronize to the time base signal (CMNCLK) on the bus in order to sample the measured values. If the period of the time base signal (CMNCLK) is shorter than the selectable range of the sampling interval (see page 1-10), the time base signal is sometimes ignored and the sampling does not occur. The delay from the time the time base signal enters the WE7521 to the time the sampling starts is approximately 10 ns (typical value*).

When using a specified input signal (Input) or the time base signal (CMNCLK) from the bus for the time base signal, an extra clock cycle of input is required in addition to the number of times the measured values are actually written to the acquisition memory. This is because the data corresponding to the first clock cycle is invalid. For example, if you wish to sample and write 100 points of measured values using the external clock (burst signal), 101 cycles of clock signal are required.

* Typical value represents a typical or average value. It is not strictly guaranteed.

Controlling the Timing of the Start of the Measurement (Arming)

When the arming signal (ARM) bus is connected to the measurement module in the trigger source/time base source/arming setting dialog box, clicking the Start button on the operation panel causes the module to enter the arming signal wait state. The measurement starts when the arming signal becomes True.

If the Repeat check box under the Start button is selected, the module enters the arming signal wait state after each measurement. When the arming signal becomes True again, the module acquires the next waveform.

1.7 Data Storage Format When in Time Stamp Mode

When in time stamp mode, the information about the input change and the time are written to the data file (a file with the .wvf extension) in 32-bit binary format when there is a change in the input as shown below. The lower eight bits make up the input change section and the upper twenty-four bits make up the time stamp data section. The time stamp data is data that is incremented every 5 ns (example: 000 ... 011 if 15 ns has elapsed) from the start of the measurement.

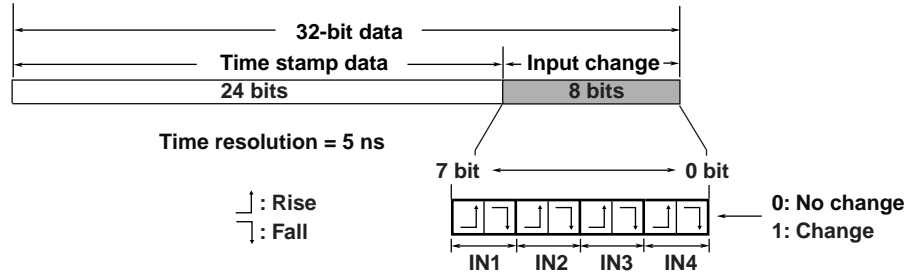

The first 32-bit data that is written upon starting the measurement is data consisting of all 0s (input change section and time stamp data section). From this point, the 32-bit data is written only when there is a change in the input.

Since the number of bits of the time stamp data is 24, the time stamp data section overflows after 83.39 ms elapses from the start of the measurement. When the time stamp data section overflows, 32-bit data consisting of all 0s in the input change section and 1 in the lowest bit of the time stamp data section are written as shown in the figure below under Overflow 1. The 32-bit data continues to be written when there is a change in the input or when the time stamp data section overflows until the measurement is stopped. By using the 24-bit data with all bits of the input change section set to 0 as upper 24-bit data and the other 24-bit data as lower 24-bit data, 48-bit time stamp data is obtained.

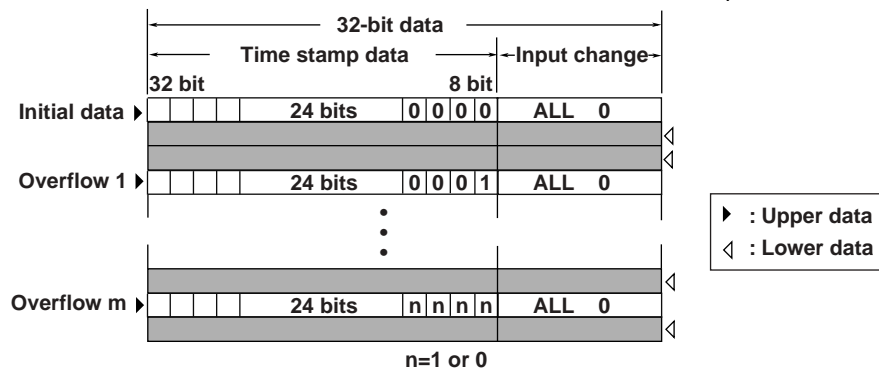

Precautions to Be Taken When Using Time Stamp Data

- The Waveform Monitor and Viewer of the WE7000 Control Software do not support this type of data.
- The number of measured values (the number of 32-bit data points) contained in the data is $\frac{\text{file size of the data file (a file with .wvf extension)}}{4}$. This number is written as Block Number in the header file (ASCII file with an .hdr extension) that is created along with the data file.
- When making measurements with the modules linked, the data file is created for each module. To distinguish the files, the name of the data file has Sn- (n: slot number) between the basic file name and the file number, as in TESTS1-00004.wvf.
- If the change in the input signal is too fast and the PC can no longer save the data, the measurement is stopped. In this case, an error message "Over Run" is displayed. As a general guideline, data can be saved for a signal that changes within 220 kHz, if (1) the CPU on the PC is a Pentium III 800 MHz, (2) communication between the PC and the measuring station is performed via the PCI optical interface card, and (3) only the rising edge is being detected on a single input on a single module.

1.8 Measurement Accuracy

Factors That Determine the Measurement Accuracy of the Counter

Accuracy expresses the amount that the measured value is offset from the true value. The factors that cause the offset include the following:

$$\text{Accuracy} = \pm \text{resolution} + \text{time base error} \pm \text{trigger level timing error} \dots (1)$$

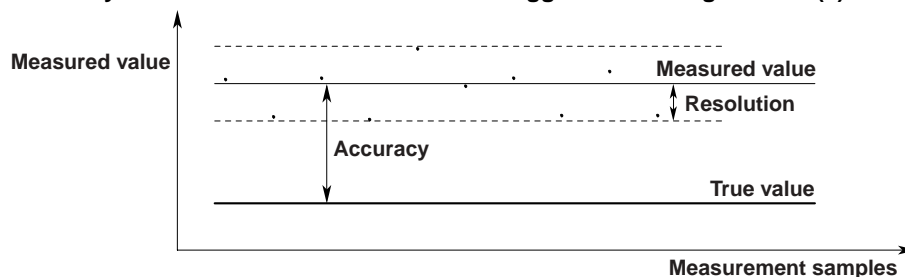

Factors That Determine the Resolution of the Counter

Resolution is the minimum unit by which two measured values can be distinguished. The factors that cause errors in time measurements are as follows:

$$\text{Resolution} = \pm 1 \text{ count error} \pm \text{trigger error} \dots (2)$$

± 1 count error

Since the internal clock of the counter that is to measure the time and the input signal is asynchronous, a quantization error of ± 1 clock cycle can occur depending on the relative timing between the clock and signal.

The figure below shows the timing of a clock signal and two patterns of input signals.

Even though the pulse width of input signal 1 and 2 are the same, a difference of 1 clock cycle results due to the timing of the signals with respect to the internal clock.

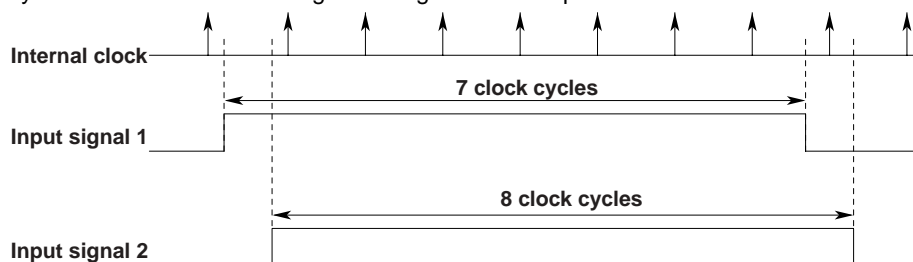

Trigger Error

For input signals with a slow rising edge such as input signals with superimposed random noise or a sinusoid of low frequency, the timing when the signal crosses the trigger level varies for each measurement. This results in measurement error. This error is called *trigger error*.

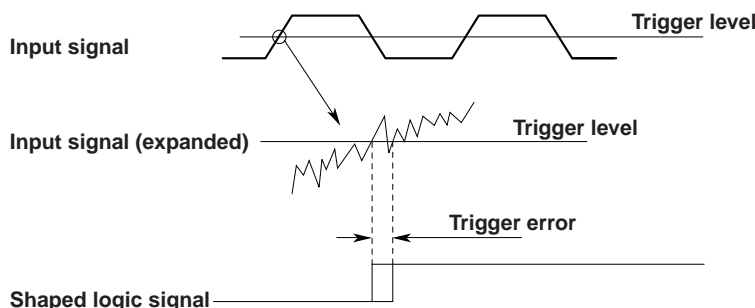

When a noise is superimposed on an input signal with a slow rise time as shown above, the signal noise causes a trigger error. The relationship between the trigger error and signal noise is expressed using the signal slew rate of the signal ($SR = \Delta v / \Delta t$) as

$$\text{Trigger error [srms]} = \frac{\sqrt{X^2 + E_n^2} [\text{Vrms}]}{SR [\text{V/s}]} \dots (3)$$

(where X and E_n are the counter input section noise and signal noise, respectively)

On this module, $X = 6 \text{ mVrms}$ (typical value).

Time Base Error

The oscillation period of the internal crystal oscillator is the time reference for measurements.

The oscillation frequency of the crystal oscillator ages with time. The aging rate of the crystal oscillator of this module is

$$\pm 1.5 \times 10^{-6}/\text{year}.$$

Therefore, the oscillation frequency of 25 MHz may have changed by up to 37.5 Hz. The error that results due to the degradation of the reference frequency is call time base error.

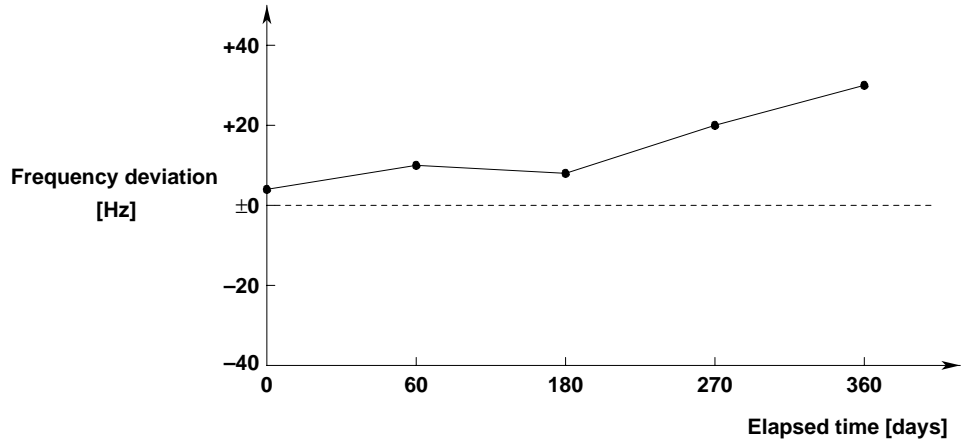

Trigger Level Timing Error

The trigger level timing error occurs when measuring the time interval. The error occurs when the trigger level accuracy and input signal A and B or the rising or falling edge of the slope vary.

Below is an example during time interval measurement. Hysteresis is applied to the trigger level to take measures against noise, but this causes timing errors. In other words, on the rising edge of the signal, the trigger is activated at a higher level than the actual specified voltage. If the rise time is slow, the trigger is delayed by the amount equal to the hysteresis width.

In addition, if the rise times of start and stop are different, the trigger level accuracy also constitutes a timing error.

Trigger level timing error is a combination of the errors caused by the hysteresis width and trigger level accuracy.

If the rise time is expressed in terms of the slew rate SR [V/μs] of the signal, the trigger level timing error is derived using the following equation.

$$\text{Trigger level timing error} = \left(\frac{1/2 \text{ hysteresis width}^*}{\text{SR (input signal A)}} - \frac{1/2 \text{ hysteresis width}^*}{\text{SR (input signal B)}} \right) \pm \frac{\text{Trigger level setting accuracy}}{\text{SR (input signal A)}} \pm \frac{\text{Trigger level setting accuracy}}{\text{SR (input signal B)}}$$

SR: Input signal slew rate for the trigger level

* When set to NORMAL, the hysteresis width is approximately 0.8 V.

As shown in the figure below, the rise time of input signal B is longer than that of input signal A. Thus, the time interval that is measured is as follows:

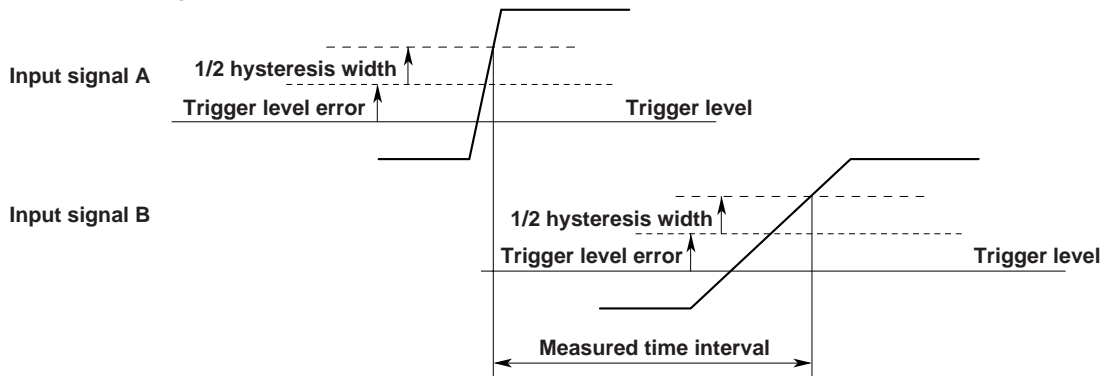

1.9 Names and Function of Sections

Front Panel

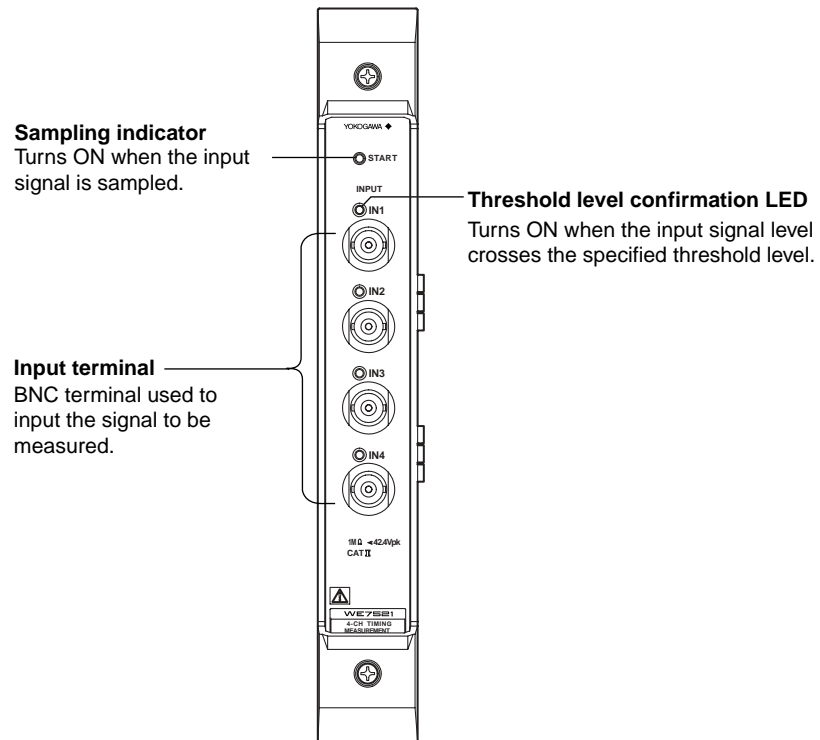

2.1 Installing the Module into the Measuring Station

Preparing to Install the Module

The measuring station comes with each slot covered with a cover plate as shown in the figure below. Verify that the power supply is not connected to the measuring station, and then loosen the module attachment screws (2 locations) and remove the cover plate from the slot where the module is going to be installed. Please note that the slot on the left end is dedicated to the communication module and therefore this module cannot be installed there.

* The following figure shows an example of the measuring station WE400.

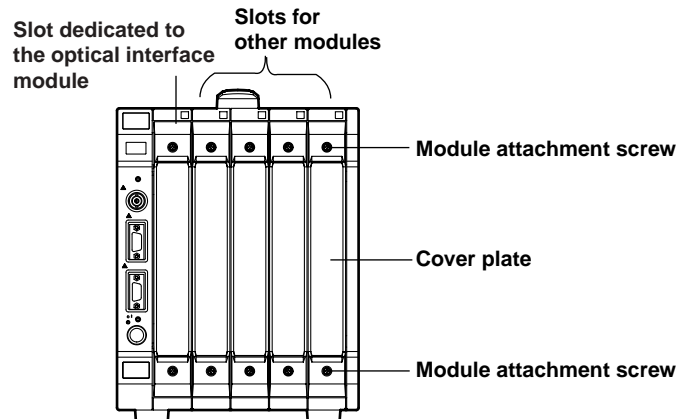

Installing the Timing Measurement Module



WARNING

- Make sure to fasten the top and bottom attachment screws. If you connect the input signal cable without fastening the attachment screws, the protective grounding of the measurement module provided by the power cord is compromised and may cause electric shock.



CAUTION

- To avoid damaging the instrument when installing modules, make sure to turn OFF the standby power switch of the measuring station.
- Be careful not to get your fingers caught in the ejection lever when inserting the module. In addition, do not put your hand inside the slot, because there are protrusions along the module guide that may injure your fingers.
- Do not remove the cover plates from unused slots. It can cause overheating and malfunction. The cover plates are also needed to minimize the influence of electromagnetic interference.

Insert the module along the guide rail of the slot from which you removed the cover plate. Insert the module until it clicks into the connector. Be careful not to get your fingers caught in the ejection lever while inserting the module. When the module is securely inserted, fasten the module attachment screws (tightening torque: 0.6 to 0.7 N-m). To remove the module, loosen the module attachment screws and pull the ejection lever from the inside to the outside. This will force the module out of the slot.

<There is an illustration on the next page.>

2.1 Installing the Module into the Measuring Station

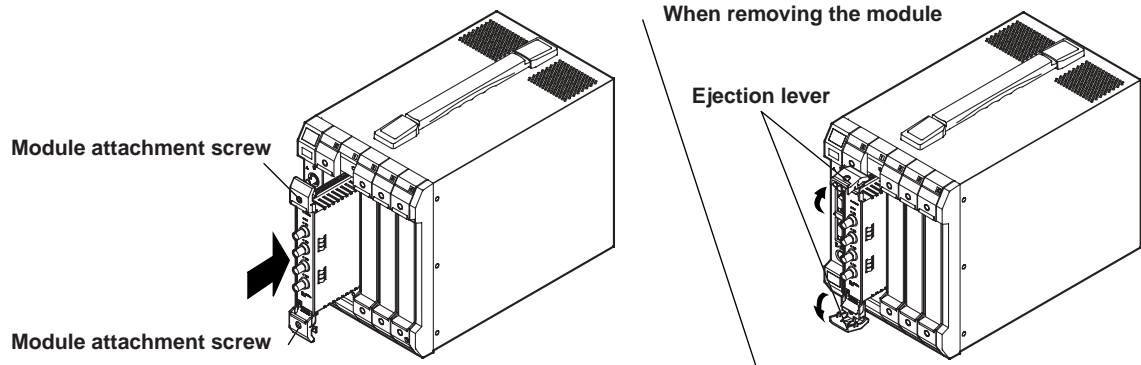

Note

When synchronizing multiple timing measurement modules for measurement (module linking), install them in adjacent slots.

2.2 Connecting the Input Cable



A BNC cable is used to input the signal to be measured. Connect the BNC cable to the input terminal (BNC terminal indicated as IN1 through IN4) on the front panel of the module. The input signal must conform to the following:

- Number of inputs: 4
- Input format: Non-isolated, unbalanced
- Input impedance: $1\text{ M}\Omega \pm 1\%$
- Maximum input voltage: $\pm 42.4\text{ V}$ (DC + ACpeak)
(Overvoltage Category CAT I and II)
- Minimum input pulse width: 50 ns (in counter mode), 200 ns (in time stamp mode)
- Minimum input edge interval: 50 ns (during up and down count)

CAUTION



- Applying a voltage exceeding the maximum input voltage indicated above can damage the input section.

3.1 Troubleshooting

- If servicing is necessary, or if the instrument is not operating correctly after performing the following corrective actions, contact your nearest YOKOGAWA dealer as listed on the back cover of this manual.
- To verify that the module is operating correctly, perform the self test as described on the next page.

Description	Probable Cause/Corrective Action	Reference Page
Module does not operate.	Check to see that the module is installed correctly into the station. Also, install the module into another slot, and check whether it will operate there. If it operates in the other slot, the measuring station is likely to have malfunctioned. If the module is installed correctly and does not operate, the connector might be bad or the IC may have malfunctioned. In either case, contact your nearest YOKOGAWA dealer to have it repaired.	2-1, *
Waveform data cannot be acquired.	Check to see that the input cables are connected properly to the BNC terminals.	2-3
Noise enters the input signal.	If the signal line and the AC power supply line are close to each other, move them apart. Also make sure that the signal line is away from the noise source. Change to a shielded signal cable if you are not already using one. If the frequency of the input signal is known, remove the frequency region above the frequency component of the input signal by setting an input filter. The influence from noise can be suppressed by properly setting the hysteresis width and direction.	– 1-8, 1-12 1-8, 1-9, 1-12
Measured values are not correct.	Check whether the ambient temperature and humidity are within the allowed ranges. If you did not allow a warm-up time of 30 minutes, try measuring again after the warm-up time has passed.	4-5
Trigger does not activate.	Check to see that the trigger conditions are set properly. If you are using the bus trigger signal, verify that the settings are correct in the trigger source/time base source/arm setting dialog box of the WE7000 Control Software. Triggers may be activated more readily by properly setting the hysteresis width and direction.	1-11, 1-12 * 1-8, 1-9
The waveform monitor does not appear.	Check to see that the waveform monitor ON/OFF button, located to the right of the Start button of the operation, is not set to OFF.	1-3, 1-4

* See the WE7000 User's Manual (IM 707001-01E).

3.2 Self Test

If you believe the module is not operating correctly, perform the self test according to the following procedure with nothing connected to the input terminals of the module being tested and the external trigger input terminal/external I/O connector of the measuring station.

Executing Self Test

1. Select **Self Test** from the **System** menu of the WE7000 Control Software.

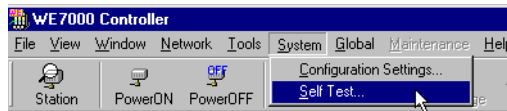

2. In the **Self Test** dialog box that appears, select the station name and enter the slot number corresponding to the module, and click **Execute**.
"Executing..." is displayed in the **Result** box.

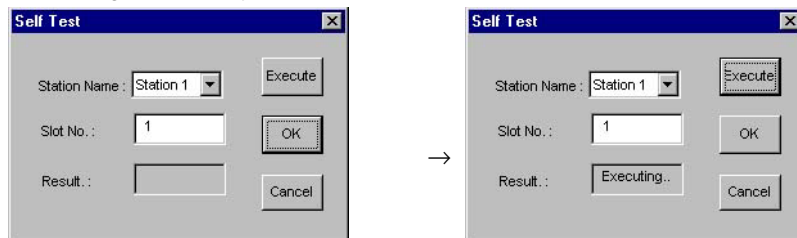

Verifying Test Results

If a value other than 0 is displayed in the Result box of the Self Test dialog box, the module is probably malfunctioning. Please contact your nearest YOKOGAWA dealer as listed on the back cover of this manual for repairs.

3.3 Maintenance

Maintenance of Parts

There are no parts in this module that require periodic replacement.

Calibration

We recommend that you calibrate the measurement module once a year to assure its measurement accuracy.

Please contact your nearest YOKOGAWA dealer to have the module calibrated.

4.1 Performance Specifications

Number of Inputs

4

Input Format

Non-isolated, unbalanced

Connector Type

BNC

Input Coupling

DC/AC

-3 dB Point During AC Coupling

10 Hz (typical value*¹)

Input Threshold Level

Set in the range ± 20 V (0.1 V resolution) for each input

Threshold Level Accuracy

 $\pm(5\%$ of the specified value + 150 mV)

Input Impedance

1 M Ω $\pm 1\%$

Input Filter

OFF/100kHz/10kHz/1kHz (-3 dB point) (typical value*¹)

Input Sensitivity

When hysteresis width is NORMAL and frequency is 1 MHz or less: 1.0 Vpp (typical value*¹)When hysteresis width is WIDE and frequency is 1 MHz or less: 3.0 Vpp (typical value*¹)

Hysteresis Width

NORMAL/WIDE

Hysteresis Direction

Center/Upper/Lower (common to all inputs)

Maximum Input Voltage

 ± 42.4 V (DC + ACpeak) (Overvoltage Category CAT I and II)

Specifications for the Counter Mode

Number of Counters

4

Measurement Slope

Rising edge or falling edge

Measurement Function

Period, time interval, totalize count, up and down count, and frequency ratio

Display Resolution

During period/time interval measurement: 5 ns

Minimum Input Pulse Width

50 ns

Minimum Input Edge Interval

For all input edges during up and down count: 50 ns

Data Width

During period/time interval measurement: 32 bits

During totalize count/up and down count/frequency ratio measurement: 29 bits*²

Acquisition Mode

Trigger, free run, gate (level), gate (edge)

Specifications for Each Measurement Function

a) Period

Measurement range: 100 ns to 20 s*³Resolution: (± 5 ns $\pm \sqrt{2}$ \times trigger error)Accuracy: Resolution \pm (time base aging \times sampling interval) ± 5 ns

4.1 Performance Specifications

b) Time interval

Measurement range: 100 ns to 20 s³

Resolution: (± 5 ns \pm input A trigger error \pm input B trigger error)

Accuracy: Resolution \pm (time base aging \times sampling interval) \pm trigger level timing error ± 5 ns

c) Totalize count

Counting capacity: 0 to 536,870,911³

Counting control: Through measurement start/stop or gate (pulse) using the input signal

Counting error: ± 1 count (when the counter is controlled through measurement start/stop)

$$\pm 1 \text{ count} \pm \frac{(\text{input B trigger error [rising]} \pm \text{input B trigger error [falling]})}{\text{input A period}}$$

(When controlled using gate/input A: signal to be measured, input B: gate signal)

d) Up and down count

Counting capacity: $-268,435,456$ to $268,435,455$ ⁴

Counting control: Through measurement start/stop or reset (Z phase) using the input signal

Counting error: ± 1 count (when the counter is controlled through measurement start/stop)

$$\pm 1 \text{ count} \pm \frac{\text{input B trigger error} \times N}{\text{input A period}} \quad (N=1, 2, 4)$$

(When controlled using reset/input A: signal to be measured, input B: reset signal)

Multiplication: $\times 1$, $\times 2$, and $\times 4$

e) Frequency ratio

Counting capacity: 0 to 536,870,911 when multiplying factor is 1, 0 to 33,554,431.9 when multiplying factor is 16, 0 to 4,194,303.99 when multiplying factor is 128, 0 to 524,287.999 when multiplying factor is 1024³

Counting control: Measurement start/stop

Counting error: ± 1 count $\pm \frac{\sqrt{2} \times \text{input B trigger error}}{\text{input A period} \times N}$ (N=1, 16, 128, 1024)

Multiplying factor: 1, 16, 128, and 1024

Acquisition Memory

Maximum record length: 1 Mpoint/CH

Memory partition: 1, 2, 4, 8, 16, 32, 64, 128, and 256 (only during trigger mode)

Sampling interval: 2 μ s to 10 s

Sampling signal source: Internal time base, bus clock, and input signal

Trigger source: Input signal, measured value, bus trigger signal of the measuring station

Hold off: Record length to 1,048,576 points (trigger mode), 1 to 1,048,576 points (gate (edge) mode)

Data hold function: Hold previous value or Update on new value⁵

Specifications for the Time Stamp Mode

Number of Inputs

4

Measurement Slope

Rising edge, falling edge, and both

Maximum Measurement Time

Approximately 360 hours (5×248 ns)

Display Resolution

5 ns

Resolution

(± 5 ns $\pm \sqrt{2} \times$ trigger error)

Accuracy

Resolution \pm (time base aging \times sampling interval) ± 5 ns

Minimum Pulse Width

200 ns

Data Format

32 bits (24-bit time stamp data + 8-bit input edge data)

Acquisition Mode

Free run only*6

Record Length

4 Mpoints

Reference Time Axis Accuracy**Frequency Stability**Aging: $\pm 1.5 \times 10^{-6}$ /year**Temperature Characteristics** $\pm 2.0 \times 10^{-6}$ (5°C to 40°C)

- *1 The typical value is a representative or standard value.
- *2 The measured data length is 29 bits, but the data width is expanded to 32 bits.
- *3 When the measurement range is exceeded, the data is set to invalid value.
- *4 When the measurement range is exceeded, the data returns to the minimum (maximum) value of the counting capacity and continues the measurement.
- *5 You can select a mode in which the previous value is held or a mode in which an invalid value is held when there is no input change during the sampling interval.
- *6 If the rate of change of input is too fast and the data cannot be saved, the measurement is stopped.

4.2 Default Values (Factory Default Settings)

Operation mode: Counter

Note

The operation mode is not reset to Counter (default) if the operation mode is set to Time Stamp and you perform operations to reset the the settings to default on the WE7000 Control Software.

Operation Mode: When Set to Counter

Coupling: DC (IN1 to IN4)

Level (threshold): 0.0 (V) (IN1 to IN4)

Filter (input filter): Off (IN1 to IN4)

Hys (hysteresis width): Check box not selected (NORMAL) (IN1 to IN4)

Function: Period (CH1 to CH4)

CH1 Source A (input to be measured/slope): IN1_Rise

CH2 Source A (input to be measured/slope): IN2_Rise

CH3 Source A (input to be measured/slope): IN3_Rise

CH4 Source A (input to be measured/slope): IN4_Rise

Acquisition Mode: Triggered

Sampling Interval: 2 us

Memory Partition: 1

Record Length: 2500

No. of Acquisitions: 1

Trig panel > Source: Input

Trig panel > Input Source (input selection when trigger source is set to Input): SlotX-IN1
(where X is the slot number in which the module is installed)

Trig panel > Slope (trigger slope): Rise

Trig panel > Pretrigger]: 0 (samples)

Trig panel > Hold Off: 2500 samples

Misc panel > Time Base: Internal

Misc panel > Data Hold (ON/OFF): On

Misc panel > Hys Type (hysteresis direction): Center

Operation Mode: When Set to Time Stamp

On (measurement ON/OFF): On (IN1 to IN4)

Coupling (input coupling): DC (IN1 to IN4)

Slope: Rise (IN1 to IN4)

Level (threshold): 0.0 (V) (IN1 to IN4)

Filter (input filter): Off (IN1 to IN4)

Hys (hysteresis width): Check box not selected (NORMAL) (IN1 to IN4)

4.3 General Specifications

Safety Standard

Complies with CSA C22.2 No.1010.1 and EN61010-1, conforms to JIS C1010-1

- Overvoltage Category CAT I and II^{*1}

- Pollution Degree 1 and 2^{*2}

^{*1} Overvoltage Categories define transient overvoltage levels, including impulse withstand voltage levels.

Overvoltage Category I : Applies to equipment supplied with electricity from a circuit containing an overvoltage control device.

Overvoltage Category II : Applies to equipment supplied with electricity from fixed installations like a distribution board.

^{*2} Pollution Degree : Applies to the degree of adhesion of a solid, liquid, or gas which deteriorates withstand voltage or surface resistivity.

Pollution Degree 1 : Applies to closed atmospheres (with no, or only dry, non-conductive pollution).

Pollution Degree 2 : Applies to normal indoor atmospheres (with only non-conductive pollution).

EMC Standards

Emission

Complying Standard

EN55011 Group 1 Class A

This product is a Class A (for commercial environment) product. Operation of this product in a residential area may cause radio interference in which case the user is required to correct the interference.

Immunity

Complying Standard

EN61326 Industrial Environment

Testing Condition

Connect with the 3m coaxial cable (3D2W).

Maximum Measuring Input Cable Length

30m

Warm-Up Time

At least 30 minutes

Operating Conditions

Same as those of the measuring station

Storage Conditions

Temperature: -20°C to 60°C

Humidity: 20% to 80% RH (no condensation)

Power Consumption

8 VA (typical value* at 100 V/50 Hz)

Weight

Approximately 0.7 kg

Dimensions

Approx. 33(W) × 243(H) × 232(D) mm (projections excluded)

Number of Used Slots

1

Standard Accessories

User's manual (this manual) (1)

* The typical value is a representative or standard value.

4.4 Dimensional Drawings

Unit: mm

WE7521 4-CH Timing Measurement Module

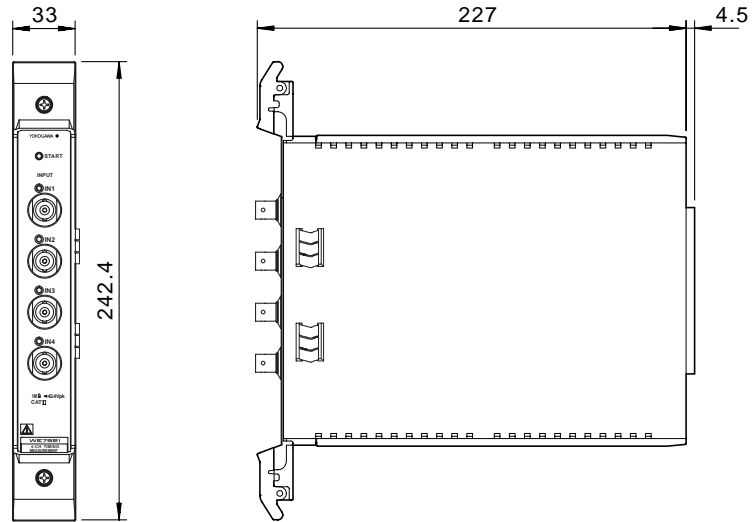

If not specified, the tolerance is $\pm 3\%$. However, in cases of less than 10 mm, the tolerance is ± 0.3 mm.

Index

Symbols

<=	1-11
=	1-11
>=	1-11

A

AC	1-8
Acquisition memory	1-2
Acquisition Mode	1-9
Acquisitions, number of	1-10
Arming	1-15

B

Both	1-5, 1-11, 1-12
Bus trigger detection	1-11
Bus trigger signal input	1-14
Bus trigger signal output	1-14
BUSCLK	1-10
BUSTRG	1-11

C

Center	1-9, 1-12
CH1 to CH4	1-5
Channel number	1-5
Cyclic	1-13

D

Data hold	1-12
DC	1-8, 1-12
Default values	4-4

E

Edge trigger	1-11
--------------	------

F

Fall	1-5, 1-11, 1-12
File number limit	1-13
Filter	1-8, 1-12
Free Run	1-9
Frequency Ratio	1-7
Function	1-5

G

Gate(Edge)	1-9
Gate(Level)	1-9

H

High	1-11
Hold Off	1-11
Hold off	1-10, 1-12
Hys	1-8, 1-12
Hys Type	1-9, 1-12
Hysteresis direction	1-9, 1-12
Hysteresis width	1-8, 1-12

I

IN1 to IN4	1-5, 1-19
Input	1-10, 1-11, 2-3
Input coupling	1-8, 1-12
Input filter	1-8, 1-12
Input Source	1-10, 1-11
Input threshold level	1-8, 1-12
Input to be measured	1-8

L

Level	1-8, 1-12
Low	1-11
Lower	1-9, 1-12

M

Measure Source	1-11
Measurement accuracy	1-17
Measurement function	1-5
Measurement, turning ON/OFF	1-12
Memory Partition	1-10
MODEL	2

N

NO.	2
No. of Acquisitions	1-10
NORMAL	1-8, 1-12

O

Off	1-12
On	1-12
Operation Mode	1-5

P

Package, contents of	2
Period	1-5
Pretrigger	1-11

R

Ratio	1-7
Record Length	1-10
Repeat	1-9
Rise	1-5, 1-11, 1-12

S

Sampling Interval	1-10
Self Test	3-2
Slope	1-10, 1-12
Source	1-11
Source A	1-8
Source B	1-8
Start	1-19
State trigger	1-11

Index

T

Threshold level	1-11
TI	1-6
Time Base	1-10
Time interval	1-6
Time Stamp	1-5
Time stamp mode	1-12
Totalize	1-6
Totalize (Gate)	1-6
Trig Type	1-11
Trigger hold off	1-11
Trigger source	1-11
Triggered	1-9
Troubleshooting	3-1
Type	1-11

U

UpDown	1-6
Upper	1-9, 1-12

W

WIDE	1-8, 1-12
------------	-----------